

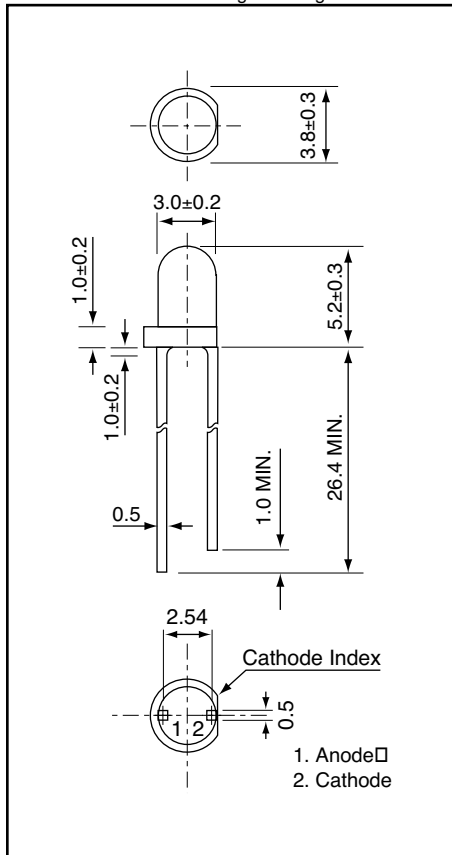

Weight: 0.12 g Unit: mm



# AND160NG

## GaP Green Light Emission

### T-1 Package (3 mm)

#### Features

- Striking Bright
- Peak wavelength ( $\lambda_p = 570$  nm) high bright emission
- All plastic mold type, clear colorless lens
- Low drive current (15 to 20 mA)
- Excellent On-Off contrast ratio
- Fast response time, capable of pulse operation

#### Maximum Ratings ( $T_a = 25^\circ\text{C}$ )

Characteristics	Symbol	Rating	Unit
Forward Current	$I_F$	30	mA
Reverse Voltage	$V_R$	5	V
Power Dissipation	$P_D$	100	mW
Operating Temperature Range	$T_{Opr}$	-40 to 85	$^\circ\text{C}$
Storage Temperature Range	$T_{Stg}$	-40 to 100	$^\circ\text{C}$

#### Electro-Optical Characteristics ( $T_a = 25^\circ\text{C}$ )

Characteristics	Symbol	Test Condition	Minimum	Typical	Maximum	Unit
Forward Voltage	$V_F$	$I_F = 20$ mA	–	2.15	2.8	V
Reverse Current	$I_R$	$V_R = 4$ V	–	–	10	$\mu\text{A}$
Luminous Intensity	$I_V$	$I_F = 20$ mA	200	250	–	mcd
Peak Emission Wavelength	$\lambda_p$	$I_F = 20$ mA	–	570	–	nm
Spectral Line Half Width	$\Delta\lambda$	$I_F = 20$ mA	–	30	–	nm
Dominant Wavelength	$\lambda_d$	$I_F = 20$ mA	–	566	–	nm
Full Viewing Angle	$\theta$	$I_V = 1/2$ Peak	–	15	–	degree

#### Precaution

Please be careful of the following:

1. Soldering temperature: 260 $^\circ\text{C}$  max  
Soldering time: 5 sec. max  
Soldering portion of lead: up to 1.6 mm from the body of the device
2. The lead can be formed up to 5 mm from the body of the device without forming stress.  
Soldering should be performed after the lead forming.

Product specifications contained herein may be changed without prior notice.

It is therefore advisable to contact Purdy Electronics before proceeding with the design of equipment incorporating this product.

